

# DDS- Planning & Zoning: Historic Review Application



Submission date: **10 March 2021, 11:44AM**  
Receipt number: **159**

## Property Information

Property Address  
Street: **222 Girard Ave**  
City: **Hartford**  
State: **CT**  
Zip Code: **06105**

Zoning District:

Parcel ID:

Property Owner: **Ikenna Nwachukwu & Ophelia Offor**

Property Owner's Address:  
Street: **222 Girard Ave**  
City: **Hartford**  
State: **CT**  
Zip Code: **06105**

Phone: **(908) 721-7413**

Email: **johnz1492@aol.com**

## Applicant

Please check if "Applicant" is the same as "Property Owner"

Name of Applicant: **Southern New England Windows**

File Date:

Address:

Street: 10 Reservoir Rd

City: Smithfield

State: RI

Zip Code: 02917

Phone:

(401) 447-7172

Email:

johnz1492@aol.com

## Primary Point of Contact

Name:

John Zuba

Phone:

(401) 447-7172

Email:

johnz1492@aol.com

Describe your application action(s) and provide as much detail as possible.

**Install (53) replacement windows. No structural changes.**

Proposed work:

Other: replacement

Current materials being repaired/replaced:

wood

Materials/products being used in work:

fibrex (wood composite)

Please upload all supporting materials and photographs below.

[Hartford 222 Girard Ave Historic Photos.pdf](#)

[Hartford Contract 222 Girard Ave.pdf](#)

[Renewal by Andersen Double-Hung Specification and Technical Manual.pdf](#)

## Signatures

Signature of Applicant:



[Link to signature](#)

Name of Applicant:

John Zuba from Southern New England Windows

Date:

3/10/2021

Signature of Property Owner:

**Agreement Document and Payment Terms**

Renewal By Andersen of Southern New England  
 Legal Name: Southern New England Windows, LLC  
 RI #36079, MA #173245, CT #0634555, Lead Firm #1237  
 10 Reservoir Rd 1 Smithfield, RI 02917  
 Phone: 401-369-1384 / Fax: 401-833-6602 / sales@renewalbyandersen.com

**Ikenna Nwachukwu & Ophelia Offer**  
 22 Girard Ave., Hartford, CT 06105  
 ikennanwachukwu94@gmail.com  
 Primary Email

Ikenna Nwachukwu & Ophelia Offer  
 22 Girard Ave.  
 Hartford, CT 06105  
 (908)721-7413  
 Primary Telephone Number  
 (908)731-2310  
 Secondary Telephone Number  
 02/06/21  
 Contract Date

Buyer(s) Name: **Ikenna Nwachukwu & Ophelia Offer**  
 Buyer(s) Street Address: **22 Girard Ave., Hartford, CT 06105**  
 Buyer(s) Primary Email: **ikennanwachukwu94@gmail.com**  
 Buyer(s) Primary Telephone Number: **(908)721-7413**  
 Buyer(s) Secondary Telephone Number: **(908)731-2310**  
 Buyer(s) Secondary Email: **ophelia.offor@gmail.com**

Buyer(s) hereby jointly and severally agrees to purchase the products and/or services of Southern New England Windows, LLC d/b/a Renewal By Andersen of Southern New England ("Contractor"), in accordance with the terms and conditions described in this Agreement Document and Payment Terms, any documents listed in the Table of Contents, and any other document attached to this Agreement Document, the terms of which are all agreed to by the parties and incorporated herein by reference (collectively, this "Agreement"). Buyer(s) hereby agrees to sign a completion certificate after Contractor has completed all work under this Agreement.

Total Job Amount:	<b>\$86,539</b>	By signing this Agreement, you acknowledge that the Balance Due and the Amount Financed must be made by personal check, bank check, credit card, or cash.
Deposit Received:	<b>\$0</b>	
Balance Due:	<b>\$86,539</b>	Estimated Start: <b>10 to 12 weeks</b>
Amount Financed:	<b>\$86,539</b>	Estimated Completion: <b>10 to 12 weeks</b>
Method of Payment:	<b>Financing</b>	We schedule installations based on the date of the signed contract and secondarily on the date in which we complete the technical measurements. The installation date that we are providing at this time is only an estimate. We will communicate an official date and time at a later date. Rain and extreme weather are the most common causes for delay.

Notes: **100% comp; 15 year 7.99% - 8.99%; Based on credit score**

Buyer(s) agrees and understands that this Agreement constitutes the entire understandings between the parties and that there are no verbal understandings, changing or modifying any of the terms of this Agreement. No alterations to or deviations from this Agreement will be valid without the signed, written consent of both the Buyer(s) and Contractor. Buyer(s) hereby acknowledges that Buyer(s) has read this Agreement, understands the terms of this Agreement, and has received a completed, signed, and dated copy of this Agreement, including the two attached Notices of Cancellation, on the date first written above and 2) was orally informed of Buyer's right to cancel this Agreement.

NOTICE TO BUYER: Do not sign this contract if blank. You are entitled to a copy of the contract at the time you sign.

**YOU, THE BUYER, MAY CANCEL THIS TRANSACTION AT ANY TIME NOT LATER THAN MIDNIGHT OF 02/10/2021 OR THE THIRD BUSINESS DAY AFTER THE DATE OF THIS TRANSACTION, WHICHEVER DATE IS LATER. SEE THE ATTACHED NOTICE OF CANCELLATION FORM FOR AN EXPLANATION OF THIS RIGHT.**

Signature of Sales Person: *Chris George*  
 Print Name of Sales Person: **Chris George**

Signature: *Ikenna Nwachukwu*  
 Print Name: **Ikenna Nwachukwu**

Signature: *Ophelia Offer*  
 Print Name: **Ophelia Offer**

UPDATED: 02/06/21 Page 2 / 23

Uploaded signature image: Hartford Contract Page 222 Girard Ave.jpg

Name of Property Owner:

Ikenna Nwachukwu & Ophelia Offer

Date:

3/10/2021



# Agreement Document and Payment Terms

dba: Renewal By Andersen of Southern New England  
Legal Name: Southern New England Windows, LLC  
RI #36079, MA #173245, CT #0634555, Lead Firm #1237  
10 Reservoir Rd I Smithfield, RI 02917  
Phone: 401-349-1384 | Fax: 401-633-6602 | sales@renewalsne.com

**Ikenna Nwachukwu & Ophelia Offor**  
22 Girard Ave.  
Hartford, CT 06105  
H: (908)721-7413  
C: (908)731-2310

**Ikenna Nwachukwu & Ophelia Offor**

**02/06/21**

Buyer(s) Name

Contract Date

**222 Girard Ave. , Hartford, CT 06105**

**(908)721-7413**

**(908)731-2310**

Buyer(s) Street Address

Primary Telephone Number

Secondary Telephone Number

**ikennanwachukwu94@gmail.com**

**ophelia.offor@gmail.com**

Primary Email

Secondary Email

Buyer(s) hereby jointly and severally agrees to purchase the products and/or services of Southern New England Windows, LLC d/b/a Renewal By Andersen of Southern New England ("Contractor"), in accordance with the terms and conditions described in this Agreement Document and Payment Terms, any documents listed in the Table of Contents, and any other document attached to this Agreement Document, the terms of which are all agreed to by the parties and incorporated herein by reference (collectively, this "Agreement"). Buyer(s) hereby agrees to sign a completion certificate after Contractor has completed all work under this Agreement.

Total Job Amount: **\$86,539**

By signing this Agreement, you acknowledge that the Balance Due, and the Amount Financed must be made by personal check, bank check, credit card, or cash.

Deposit Received: **\$0**

Balance Due: **\$86,539**

Estimated Start:  
**10 to 12 weeks**

Estimated Completion:  
**10 to 12 weeks**

Amount Financed: **\$86,539**

Method of Payment: **Financing**

We schedule installations based on the date of the signed contract and secondarily on the date in which we complete the technical measurements. The installation date that we are providing at this time is only an estimate. We will communicate an official date and time at a later date. Rain and extreme weather are the most common causes for delay.

Notes: **100% comp; 15 year 7.99% - 8.99%; Based on credit score**

Buyer(s) agrees and understands that this Agreement constitutes the entire understandings between the parties and that there are no verbal understandings changing or modifying any of the terms of this Agreement. No alterations to or deviations from this Agreement will be valid without the signed, written consent of both the Buyer(s) and Contractor. Buyer(s) hereby acknowledges that Buyer(s) 1) has read this Agreement, understands the terms of this Agreement, and has received a completed, signed, and dated copy of this Agreement, including the two attached Notices of Cancellation, on the date first written above and 2) was orally informed of Buyer's right to cancel this Agreement.

NOTICE TO BUYER: Do not sign this contract if blank. You are entitled to a copy of the contract at the time you sign.

**YOU, THE BUYER, MAY CANCEL THIS TRANSACTION AT ANY TIME NOT LATER THAN MIDNIGHT OF 02/10/2021 OR THE THIRD BUSINESS DAY AFTER THE DATE OF THIS TRANSACTION, WHICHEVER DATE IS LATER. SEE THE ATTACHED NOTICE OF CANCELLATION FORM FOR AN EXPLANATION OF THIS RIGHT.**

Signature of Sales Person

Signature

Signature

**Chris George**

**Ikenna Nwachukwu**

**Ophelia Offor**

Print Name of Sales Person

Print Name

Print Name





# Itemized Order Receipt

dba: Renewal By Andersen of Southern New England

Legal Name: Southern New England Windows, LLC

RI #36079, MA #173245, CT #0634555, Lead Firm #1237

10 Reservoir Rd I Smithfield, RI 02917

Phone: 401-349-1384 | Fax: 401-633-6602 | sales@renewalsne.com

Ikenna Nwachukwu & Ophelia Offor

22 Girard Ave.

Hartford, CT 06105

H: (908)721-7413

C: (908)731-2310

ID#:	ROOM:	DETAILS:
	all DB	<p><b>Misc:</b> Misc, TO CONSTRUCTION DEPARTMENT:, Insulate weight pockets</p> <hr/> <p><b>Misc:</b> Misc, THANK YOU!, As a reminder, it is the customer's responsibility to do any painting, staining or touch up work after installation. We appreciate your business and look forward to exceeding your expectations.</p> <hr/> <p><b>Misc:</b> Misc, PERMIT, Customer has paid \$2175.00 for Renewal by Andersen to secure a building permit for their project. Permit fees are non-refundable once Renewal By Andersen applies for a permit.</p> <hr/> <p><b>Misc:</b> Misc, GLASS LOSS, When installing any replacement window, due to different frame design, glass loss is typical. By signing the agreement, you agree that glass loss was discussed and you fully understand there will be less visible glass with new windows.</p> <hr/>
101	Laundry	<p><b>Window:</b> Double-Hung, 1:1, Slope Sill Insert, Exterior Black, Interior Black, <b>Glass:</b> All Sash: High Performance, No Pattern, <b>Hardware:</b> Black, Standard Color Hand Lift, <b>Screen:</b> Fiberglass, Full Screen, <b>Grille Style:</b> Grilles Between Glass (GBG), <b>Grille Pattern:</b> Sash 1: Colonial 3w x 2h, Sash 2: No Grille, <b>Misc:</b> None</p> <hr/>



# Itemized Order Receipt

dba: Renewal By Andersen of Southern New England  
Legal Name: Southern New England Windows, LLC  
**RI #36079, MA #173245, CT #0634555, Lead Firm #1237**  
10 Reservoir Rd | Smithfield, RI 02917  
Phone: 401-349-1384 | Fax: 401-633-6602 | sales@renewalsne.com

**Ikenna Nwachukwu & Ophelia Offor**  
22 Girard Ave.  
Hartford, CT 06105  
H: (908)721-7413  
C: (908)731-2310

ID#:	ROOM:	DETAILS:
102	Laundry	<b>Window:</b> Double-Hung, 1:1, Slope Sill Insert, Exterior Black, Interior Black, <b>Glass:</b> All Sash: High Performance, No Pattern, <b>Hardware:</b> Black, Standard Color Hand Lift, <b>Screen:</b> Fiberglass, Full Screen, <b>Grille Style:</b> Grilles Between Glass (GBG), <b>Grille Pattern:</b> Sash 1: Colonial 3w x 2h, Sash 2: No Grille, <b>Misc:</b> None
103	butler	<b>Window:</b> Casement, Single, Right, Base Frame, Exterior Black, Interior Black, <b>Glass:</b> All Sash: High Performance, No Pattern, <b>Hardware:</b> Black, <b>Screen:</b> Fiberglass, Full Screen, <b>Grille Style:</b> Grilles Between Glass (GBG), <b>Grille Pattern:</b> All Sash: Colonial 3w x 3h, <b>Misc:</b> NEW Int. Stops
104	dining	<b>Window:</b> Double-Hung, 1:1, Slope Sill Insert, Traditional Checkrail, Exterior Black, Interior Black, <b>Glass:</b> All Sash: High Performance, No Pattern, <b>Hardware:</b> Black, Standard Color Hand Lift, <b>Screen:</b> Fiberglass, Full Screen, <b>Grille Style:</b> Grilles Between Glass (GBG), <b>Grille Pattern:</b> Sash 1: Colonial 3w x 2h, Sash 2: No Grille, <b>Misc:</b> None
105	dining	<b>Window:</b> Double-Hung, 1:1, Slope Sill Insert, Traditional Checkrail, Exterior Black, Interior Black, <b>Glass:</b> All Sash: High Performance, No Pattern, <b>Hardware:</b> Black, Standard Color Hand Lift, <b>Screen:</b> Fiberglass, Full Screen, <b>Grille Style:</b> Grilles Between Glass (GBG), <b>Grille Pattern:</b> Sash 1: Colonial 3w x 2h, Sash 2: No Grille, <b>Misc:</b> None



# Itemized Order Receipt

dba: Renewal By Andersen of Southern New England  
Legal Name: Southern New England Windows, LLC  
**RI #36079, MA #173245, CT #0634555, Lead Firm #1237**  
10 Reservoir Rd | Smithfield, RI 02917  
Phone: 401-349-1384 | Fax: 401-633-6602 | sales@renewalsne.com

**Ikenna Nwachukwu & Ophelia Offor**  
22 Girard Ave.  
Hartford, CT 06105  
H: (908)721-7413  
C: (908)731-2310

ID#:	ROOM:	DETAILS:
106	dining	<b>Window:</b> Double-Hung, 1:1, Slope Sill Insert, Traditional Checkrail, Exterior Black, Interior Black, <b>Glass:</b> All Sash: High Performance, No Pattern, <b>Hardware:</b> Black, Standard Color Hand Lift, <b>Screen:</b> Fiberglass, Full Screen, <b>Grille Style:</b> Grilles Between Glass (GBG), <b>Grille Pattern:</b> Sash 1: Colonial 3w x 2h, Sash 2: No Grille, <b>Misc:</b> None
107	dining	<b>Window:</b> Double-Hung, 1:1, Slope Sill Insert, Traditional Checkrail, Exterior Black, Interior Black, <b>Glass:</b> All Sash: High Performance, No Pattern, <b>Hardware:</b> Black, Standard Color Hand Lift, <b>Screen:</b> Fiberglass, Full Screen, <b>Grille Style:</b> Grilles Between Glass (GBG), <b>Grille Pattern:</b> Sash 1: Colonial 3w x 2h, Sash 2: No Grille, <b>Misc:</b> None
108	kitchen	<b>Window:</b> Casement, Single, Right, Base Frame, Exterior Black, Interior Black, <b>Glass:</b> All Sash: High Performance, No Pattern, <b>Hardware:</b> Black, <b>Screen:</b> Fiberglass, Full Screen, <b>Grille Style:</b> Grilles Between Glass (GBG), <b>Grille Pattern:</b> All Sash: Colonial 3w x 2h, <b>Misc:</b> NEW Int. Stops, FDL Mimic Rail - Horizontal, Matches up with GBG and FDL grills only
109	kitchen	<b>Window:</b> Casement, Single, Right, Base Frame, Exterior Black, Interior Black, <b>Glass:</b> All Sash: High Performance, No Pattern, <b>Hardware:</b> Black, <b>Screen:</b> Fiberglass, Full Screen, <b>Grille Style:</b> Grilles Between Glass (GBG), <b>Grille Pattern:</b> All Sash: Colonial 3w x 2h, <b>Misc:</b> NEW Int. Stops, FDL Mimic Rail - Horizontal, Matches up with GBG and FDL grills only



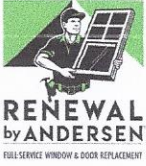

# Itemized Order Receipt

dba: Renewal By Andersen of Southern New England  
Legal Name: Southern New England Windows, LLC  
RI #36079, MA #173245, CT #0634555, Lead Firm #1237  
10 Reservoir Rd | Smithfield, RI 02917  
Phone: 401-349-1384 | Fax: 401-633-6602 | sales@renewalsne.com

**Ikenna Nwachukwu & Ophelia Offor**  
22 Girard Ave.  
Hartford, CT 06105  
H: (908)721-7413  
C: (908)731-2310

**ID#: ROOM:**

**DETAILS:**

**110** 2nd Sitting Room

**Window:** Gliding, Double, 1:1, Active / Passive, Base Frame, Exterior Black, Interior Black, **Glass:** All Sash: High Performance, No Pattern, **Hardware:** Black, Standard Color Hand Pull, **Screen:** Fiberglass, Half Screen, **Grille Style:** Grilles Between Glass (GBG), **Grille Pattern:** All Sash: Colonial 3w x 4h, **Misc:** NEW Int. Stops, L trim

**111** 2nd Sitting Room

**Window:** Gliding, Double, 1:1, Active / Passive, Base Frame, Exterior Black, Interior Black, **Glass:** All Sash: High Performance, No Pattern, **Hardware:** Black, Standard Color Hand Pull, **Screen:** Fiberglass, Half Screen, **Grille Style:** Grilles Between Glass (GBG), **Grille Pattern:** All Sash: Colonial 3w x 4h, **Misc:** NEW Int. Stops, L trim

**112** 2nd Sitting Room

**Window:** Gliding, Triple, 1:1:1, Base Frame, Exterior Black, Interior Black, **Glass:** All Sash: High Performance, No Pattern, **Hardware:** Black, Standard Color Hand Pull, **Screen:** Fiberglass, Full Screen, **Grille Style:** Grilles Between Glass (GBG), **Grille Pattern:** All Sash: Colonial 3w x 4h, **Misc:** NEW Int. Stops, L trim

**113** Formal Living

**Window:** Double-Hung, 1:1, Slope Sill Insert, Traditional Checkrail, Exterior Black, Interior Black, **Glass:** All Sash: High Performance, No Pattern, **Hardware:** Black, Standard Color Hand Lift, **Screen:** Fiberglass, Full Screen, **Grille Style:** Grilles Between Glass (GBG), **Grille Pattern:** Sash 1: Colonial 3w x 2h, Sash 2: No Grille, **Misc:** Misc. Unit Note



# Itemized Order Receipt

dba: Renewal By Andersen of Southern New England

Legal Name: Southern New England Windows, LLC

RI #36079, MA #173245, CT #0634555, Lead Firm #1237

10 Reservoir Rd | Smithfield, RI 02917

Phone: 401-349-1384 | Fax: 401-633-6602 | sales@renewalsne.com

Ikenna Nwachukwu & Ophelia Offor

22 Girard Ave.

Hartford, CT 06105

H: (908)721-7413

C: (908)731-2310

ID#:	ROOM:	DETAILS:
114	Formal Living	<b>Window:</b> Double-Hung, 1:1, Slope Sill Insert, Traditional Checkrail, Exterior Black, Interior Black, <b>Glass:</b> All Sash: High Performance, No Pattern, <b>Hardware:</b> Black, Standard Color Hand Lift, <b>Screen:</b> Fiberglass, Full Screen, <b>Grille Style:</b> Grilles Between Glass (GBG), <b>Grille Pattern:</b> Sash 1: Colonial 3w x 2h, Sash 2: No Grille, <b>Misc:</b> None
115	Formal Living	<b>Window:</b> Double-Hung, 1:1, Slope Sill Insert, Traditional Checkrail, Exterior Black, Interior Black, <b>Glass:</b> All Sash: High Performance, No Pattern, <b>Hardware:</b> Black, Standard Color Hand Lift, <b>Screen:</b> Fiberglass, Full Screen, <b>Grille Style:</b> Grilles Between Glass (GBG), <b>Grille Pattern:</b> Sash 1: Colonial 3w x 2h, Sash 2: No Grille, <b>Misc:</b> None
116	Office	<b>Window:</b> Double-Hung, 1:1, Slope Sill Insert, Traditional Checkrail, Exterior Black, Interior Black, <b>Glass:</b> All Sash: High Performance, No Pattern, <b>Hardware:</b> Black, Standard Color Hand Lift, <b>Screen:</b> Fiberglass, Full Screen, <b>Grille Style:</b> Grilles Between Glass (GBG), <b>Grille Pattern:</b> Sash 1: Colonial 3w x 2h, Sash 2: No Grille, <b>Misc:</b> None
117	Office	<b>Window:</b> Double-Hung, 1:1, Slope Sill Insert, Traditional Checkrail, Exterior Black, Interior Black, <b>Glass:</b> All Sash: High Performance, No Pattern, <b>Hardware:</b> Black, Standard Color Hand Lift, <b>Screen:</b> Fiberglass, Full Screen, <b>Grille Style:</b> Grilles Between Glass (GBG), <b>Grille Pattern:</b> Sash 1: Colonial 3w x 2h, Sash 2: No Grille, <b>Misc:</b> None



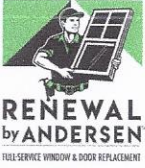

# Itemized Order Receipt

dba: Renewal By Andersen of Southern New England

Legal Name: Southern New England Windows, LLC

RI #36079, MA #173245, CT #0634555, Lead Firm #1237

10 Reservoir Rd | Smithfield, RI 02917

Phone: 401-349-1384 | Fax: 401-633-6602 | sales@renewalsne.com

Ikenna Nwachukwu & Ophelia Offor

22 Girard Ave.

Hartford, CT 06105

H: (908)721-7413

C: (908)731-2310

ID#: ROOM:

DETAILS:

118 Office

**Window:** Double-Hung, 1:1, Slope Sill Insert, Traditional Checkrail, Exterior Black, Interior Black, **Glass:** All Sash: High Performance, No Pattern, **Hardware:** Black, Standard Color Hand Lift, **Screen:** Fiberglass, Full Screen, **Grille Style:** Grilles Between Glass (GBG), **Grille Pattern:** Sash 1: Colonial 3w x 2h, Sash 2: No Grille, **Misc:** None

119 1st Bath

**Window:** Double-Hung, 1:1, Slope Sill Insert, Traditional Checkrail, Exterior Black, Interior Black, **Glass:** Sash 1: High Performance, No Pattern, Sash 2: High Performance, No Pattern, Tempered Glass, **Hardware:** Black, Standard Color Hand Lift, **Screen:** Fiberglass, Full Screen, **Grille Style:** Grilles Between Glass (GBG), **Grille Pattern:** Sash 1: Colonial 3w x 2h, Sash 2: No Grille, **Misc:** None

120 m bed

**Window:** Double-Hung, 1:1, Slope Sill Insert, Traditional Checkrail, Exterior Black, Interior Black, **Glass:** All Sash: High Performance, No Pattern, **Hardware:** Black, Standard Color Hand Lift, **Screen:** Fiberglass, Full Screen, **Grille Style:** Grilles Between Glass (GBG), **Grille Pattern:** Sash 1: Colonial 3w x 2h, Sash 2: No Grille, **Misc:** None

121 m bed

**Window:** Double-Hung, 1:1, Slope Sill Insert, Traditional Checkrail, Exterior Black, Interior Black, **Glass:** All Sash: High Performance, No Pattern, **Hardware:** Black, Standard Color Hand Lift, **Screen:** Fiberglass, Full Screen, **Grille Style:** Grilles Between Glass (GBG), **Grille Pattern:** Sash 1: Colonial 3w x 2h, Sash 2: No Grille, **Misc:** None



# Itemized Order Receipt

dba: Renewal By Andersen of Southern New England  
Legal Name: Southern New England Windows, LLC  
**RI #36079, MA #173245, CT #0634555, Lead Firm #1237**  
10 Reservoir Rd | Smithfield, RI 02917  
Phone: 401-349-1384 | Fax: 401-633-6602 | sales@renewalsne.com

**Ikenna Nwachukwu & Ophelia Offor**  
22 Girard Ave.  
Hartford, CT 06105  
H: (908)721-7413  
C: (908)731-2310

ID#:	ROOM:	DETAILS:
122	m bath	<b>Window:</b> Double-Hung, 1:1, Slope Sill Insert, Traditional Checkrail, Exterior Black, Interior Black, <b>Glass:</b> Sash 1: High Performance, No Pattern, Sash 2: High Performance, No Pattern, Tempered Glass, <b>Hardware:</b> Black, Standard Color Hand Lift, <b>Screen:</b> Fiberglass, Full Screen, <b>Grille Style:</b> Grilles Between Glass (GBG), <b>Grille Pattern:</b> Sash 1: Colonial 3w x 2h, Sash 2: No Grille, <b>Misc:</b> None
123	m bath	<b>Window:</b> Double-Hung, 1:1, Slope Sill Insert, Traditional Checkrail, Exterior Black, Interior Black, <b>Glass:</b> Sash 1: High Performance, No Pattern, Sash 2: High Performance, No Pattern, Tempered Glass, <b>Hardware:</b> Black, Standard Color Hand Lift, <b>Screen:</b> Fiberglass, Full Screen, <b>Grille Style:</b> Grilles Between Glass (GBG), <b>Grille Pattern:</b> Sash 1: Colonial 3w x 2h, Sash 2: No Grille, <b>Misc:</b> None
124	m clo	<b>Window:</b> Double-Hung, 1:1, Slope Sill Insert, Traditional Checkrail, Exterior Black, Interior Black, <b>Glass:</b> All Sash: High Performance, No Pattern, <b>Hardware:</b> Black, Standard Color Hand Lift, <b>Screen:</b> Fiberglass, Full Screen, <b>Grille Style:</b> Grilles Between Glass (GBG), <b>Grille Pattern:</b> Sash 1: Colonial 3w x 2h, Sash 2: No Grille, <b>Misc:</b> None
125	m bed	<b>Window:</b> Double-Hung, 1:1, Slope Sill Insert, Traditional Checkrail, Exterior Black, Interior Black, <b>Glass:</b> All Sash: High Performance, No Pattern, <b>Hardware:</b> Black, Standard Color Hand Lift, <b>Screen:</b> Fiberglass, Full Screen, <b>Grille Style:</b> Grilles Between Glass (GBG), <b>Grille Pattern:</b> Sash 1: Colonial 3w x 2h, Sash 2: No Grille, <b>Misc:</b> None

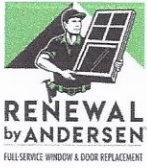

# Itemized Order Receipt

dba: Renewal By Andersen of Southern New England

Legal Name: Southern New England Windows, LLC

RI #36079, MA #173245, CT #0634555, Lead Firm #1237

10 Reservoir Rd | Smithfield, RI 02917

Phone: 401-349-1384 | Fax: 401-633-6602 | sales@renewalsne.com

Ikenna Nwachukwu & Ophelia Offor

22 Girard Ave.

Hartford, CT 06105

H: (908)721-7413

C: (908)731-2310

ID#:	ROOM:	DETAILS:
126	m bed	<b>Window:</b> Double-Hung, 1:1, Slope Sill Insert, Traditional Checkrail, Exterior Black, Interior Black, <b>Glass:</b> All Sash: High Performance, No Pattern, <b>Hardware:</b> Black, Standard Color Hand Lift, <b>Screen:</b> Fiberglass, Full Screen, <b>Grille Style:</b> Grilles Between Glass (GBG), <b>Grille Pattern:</b> Sash 1: Colonial 3w x 2h, Sash 2: No Grille, <b>Misc:</b> None
127	bath 2	<b>Window:</b> Double-Hung, 1:1, Slope Sill Insert, Traditional Checkrail, Exterior Black, Interior Black, <b>Glass:</b> Sash 1: High Performance, No Pattern, Sash 2: High Performance, No Pattern, Tempered Glass, <b>Hardware:</b> Black, Standard Color Hand Lift, <b>Screen:</b> Fiberglass, Full Screen, <b>Grille Style:</b> Grilles Between Glass (GBG), <b>Grille Pattern:</b> Sash 1: Colonial 3w x 2h, Sash 2: No Grille, <b>Misc:</b> None
128	bed 2	<b>Window:</b> Double-Hung, 1:1, Slope Sill Insert, Traditional Checkrail, Exterior Black, Interior Black, <b>Glass:</b> All Sash: High Performance, No Pattern, <b>Hardware:</b> Black, Standard Color Hand Lift, <b>Screen:</b> Fiberglass, Full Screen, <b>Grille Style:</b> Grilles Between Glass (GBG), <b>Grille Pattern:</b> Sash 1: Colonial 3w x 2h, Sash 2: No Grille, <b>Misc:</b> None
129	bed 2	<b>Window:</b> Double-Hung, 1:1, Slope Sill Insert, Traditional Checkrail, Exterior Black, Interior Black, <b>Glass:</b> All Sash: High Performance, No Pattern, <b>Hardware:</b> Black, Standard Color Hand Lift, <b>Screen:</b> Fiberglass, Full Screen, <b>Grille Style:</b> Grilles Between Glass (GBG), <b>Grille Pattern:</b> Sash 1: Colonial 3w x 2h, Sash 2: No Grille, <b>Misc:</b> None



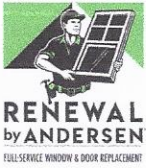

# Itemized Order Receipt

dba: Renewal By Andersen of Southern New England

Legal Name: Southern New England Windows, LLC

RI #36079, MA #173245, CT #0634555, Lead Firm #1237

10 Reservoir Rd | Smithfield, RI 02917

Phone: 401-349-1384 | Fax: 401-633-6602 | sales@renewalsne.com

Ikenna Nwachukwu & Ophelia Offor

22 Girard Ave.

Hartford, CT 06105

H: (908)721-7413

C: (908)731-2310

ID#: ROOM:

DETAILS:

130 bed 2

**Window:** Double-Hung, 1:1, Slope Sill Insert, Traditional Checkrail, Exterior Black, Interior Black, **Glass:** All Sash: High Performance, No Pattern, **Hardware:** Black, Standard Color Hand Lift, **Screen:** Fiberglass, Full Screen, **Grille Style:** Grilles Between Glass (GBG), **Grille Pattern:** Sash 1: Colonial 3w x 2h, Sash 2: No Grille, **Misc:** None

131 bath 3

**Window:** Double-Hung, 1:1, Slope Sill Insert, Traditional Checkrail, Exterior Black, Interior Black, **Glass:** Sash 1: High Performance, No Pattern, Sash 2: High Performance, No Pattern, Tempered Glass, **Hardware:** Black, Standard Color Hand Lift, **Screen:** Fiberglass, Full Screen, **Grille Style:** Grilles Between Glass (GBG), **Grille Pattern:** Sash 1: Colonial 3w x 2h, Sash 2: No Grille, **Misc:** None

132 bed 3

**Window:** Double-Hung, 1:1, Slope Sill Insert, Traditional Checkrail, Exterior Black, Interior Black, **Glass:** All Sash: High Performance, No Pattern, **Hardware:** Black, Standard Color Hand Lift, **Screen:** Fiberglass, Full Screen, **Grille Style:** Grilles Between Glass (GBG), **Grille Pattern:** Sash 1: Colonial 3w x 2h, Sash 2: No Grille, **Misc:** None

133 bed 3

**Window:** Double-Hung, 1:1, Slope Sill Insert, Traditional Checkrail, Exterior Black, Interior Black, **Glass:** All Sash: High Performance, No Pattern, **Hardware:** Black, Standard Color Hand Lift, **Screen:** Fiberglass, Full Screen, **Grille Style:** Grilles Between Glass (GBG), **Grille Pattern:** Sash 1: Colonial 3w x 2h, Sash 2: No Grille, **Misc:** None



# Itemized Order Receipt

dba: Renewal By Andersen of Southern New England

Legal Name: Southern New England Windows, LLC

RI #36079, MA #173245, CT #0634555, Lead Firm #1237

10 Reservoir Rd I Smithfield, RI 02917

Phone: 401-349-1384 | Fax: 401-633-6602 | sales@renewalsne.com

Ikenna Nwachukwu & Ophelia Offor

22 Girard Ave.

Hartford, CT 06105

H: (908)721-7413

C: (908)731-2310

ID#:	ROOM:	DETAILS:
134	bed 3	<b>Window:</b> Double-Hung, 1:1, Slope Sill Insert, Traditional Checkrail, Exterior Black, Interior Black, <b>Glass:</b> All Sash: High Performance, No Pattern, <b>Hardware:</b> Black, Standard Color Hand Lift, <b>Screen:</b> Fiberglass, Full Screen, <b>Grille Style:</b> Grilles Between Glass (GBG), <b>Grille Pattern:</b> Sash 1: Colonial 3w x 2h, Sash 2: No Grille, <b>Misc:</b> None
135	bed 4	<b>Window:</b> Double-Hung, 1:1, Slope Sill Insert, Traditional Checkrail, Exterior Black, Interior Black, <b>Glass:</b> All Sash: High Performance, No Pattern, <b>Hardware:</b> Black, Standard Color Hand Lift, <b>Screen:</b> Fiberglass, Full Screen, <b>Grille Style:</b> Grilles Between Glass (GBG), <b>Grille Pattern:</b> Sash 1: Colonial 3w x 2h, Sash 2: No Grille, <b>Misc:</b> None
136	bed 4	<b>Window:</b> Double-Hung, 1:1, Slope Sill Insert, Traditional Checkrail, Exterior Black, Interior Black, <b>Glass:</b> All Sash: High Performance, No Pattern, <b>Hardware:</b> Black, Standard Color Hand Lift, <b>Screen:</b> Fiberglass, Full Screen, <b>Grille Style:</b> Grilles Between Glass (GBG), <b>Grille Pattern:</b> Sash 1: Colonial 3w x 2h, Sash 2: No Grille, <b>Misc:</b> None
137	bed 4	<b>Window:</b> Double-Hung, 1:1, Slope Sill Insert, Traditional Checkrail, Exterior Black, Interior Black, <b>Glass:</b> All Sash: High Performance, No Pattern, <b>Hardware:</b> Black, Standard Color Hand Lift, <b>Screen:</b> Fiberglass, Full Screen, <b>Grille Style:</b> Grilles Between Glass (GBG), <b>Grille Pattern:</b> Sash 1: Colonial 3w x 2h, Sash 2: No Grille, <b>Misc:</b> None



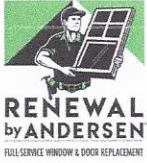

# Itemized Order Receipt

dba: Renewal By Andersen of Southern New England

Legal Name: Southern New England Windows, LLC

RI #36079, MA #173245, CT #0634555, Lead Firm #1237

10 Reservoir Rd I Smithfield, RI 02917

Phone: 401-349-1384 | Fax: 401-633-6602 | sales@renewaisne.com

Ikenna Nwachukwu & Ophelia Offor

22 Girard Ave.

Hartford, CT 06105

H: (908)721-7413

C: (908)731-2310

ID#:	ROOM:	DETAILS:
138	bath 4	<b>Window:</b> Double-Hung, 1:1, Slope Sill Insert, Traditional Checkrail, Exterior Black, Interior Black, <b>Glass:</b> Sash 1: High Performance, No Pattern, Sash 2: High Performance, No Pattern, Tempered Glass, <b>Hardware:</b> Black, Standard Color Hand Lift, <b>Screen:</b> Fiberglass, Full Screen, <b>Grille Style:</b> Grilles Between Glass (GBG), <b>Grille Pattern:</b> Sash 1: Colonial 3w x 2h, Sash 2: No Grille, <b>Misc:</b> None
139	bed 5	<b>Window:</b> Double-Hung, 1:1, Slope Sill Insert, Traditional Checkrail, Exterior Black, Interior Black, <b>Glass:</b> All Sash: High Performance, No Pattern, <b>Hardware:</b> Black, Standard Color Hand Lift, <b>Screen:</b> Fiberglass, Full Screen, <b>Grille Style:</b> Grilles Between Glass (GBG), <b>Grille Pattern:</b> Sash 1: Colonial 3w x 2h, Sash 2: No Grille, <b>Misc:</b> None
140	bed 5	<b>Window:</b> Double-Hung, 1:1, Slope Sill Insert, Traditional Checkrail, Exterior Black, Interior Black, <b>Glass:</b> All Sash: High Performance, No Pattern, <b>Hardware:</b> Black, Standard Color Hand Lift, <b>Screen:</b> Fiberglass, Full Screen, <b>Grille Style:</b> Grilles Between Glass (GBG), <b>Grille Pattern:</b> Sash 1: Colonial 3w x 2h, Sash 2: No Grille, <b>Misc:</b> None
141	bed 5	<b>Window:</b> Double-Hung, 1:1, Slope Sill Insert, Traditional Checkrail, Exterior Black, Interior Black, <b>Glass:</b> All Sash: High Performance, No Pattern, <b>Hardware:</b> Black, Standard Color Hand Lift, <b>Screen:</b> Fiberglass, Full Screen, <b>Grille Style:</b> Grilles Between Glass (GBG), <b>Grille Pattern:</b> Sash 1: Colonial 3w x 2h, Sash 2: No Grille, <b>Misc:</b> None



# Itemized Order Receipt

dba: Renewal By Andersen of Southern New England

Legal Name: Southern New England Windows, LLC

RI #36079, MA #173245, CT #0634555, Lead Firm #1237

10 Reservoir Rd | Smithfield, RI 02917

Phone: 401-349-1384 | Fax: 401-633-6602 | sales@renewalsne.com

Ikenna Nwachukwu & Ophelia Offor

22 Girard Ave.

Hartford, CT 06105

H: (908)721-7413

C: (908)731-2310

ID#: ROOM:

DETAILS:

142 Attic

**Specialty:** Circle Top, Base Frame, Exterior Black, Interior Black, **Glass:** All Sash: High Performance, No Pattern, **Grille Style:** Grilles Between Glass (GBG), **Grille Pattern:** All Sash: Renaissance 6w, **Misc:** None

143 bath 5

**Window:** Double-Hung, 1:1, Slope Sill Insert, Traditional Checkrail, Exterior Black, Interior Black, **Glass:** Sash 1: High Performance, No Pattern, Sash 2: High Performance, No Pattern, Tempered Glass, **Hardware:** Black, Standard Color Hand Lift, **Screen:** Fiberglass, Full Screen, **Grille Style:** Grilles Between Glass (GBG), **Grille Pattern:** Sash 1: Colonial 3w x 2h, Sash 2: No Grille, **Misc:** None

144 bed 6

**Window:** Double-Hung, 1:1, Slope Sill Insert, Traditional Checkrail, Exterior Black, Interior Black, **Glass:** All Sash: High Performance, No Pattern, **Hardware:** Black, Standard Color Hand Lift, **Screen:** Fiberglass, Full Screen, **Grille Style:** Grilles Between Glass (GBG), **Grille Pattern:** Sash 1: Colonial 3w x 2h, Sash 2: No Grille, **Misc:** None

145 bed 6

**Window:** Double-Hung, 1:1, Slope Sill Insert, Traditional Checkrail, Exterior Black, Interior Black, **Glass:** All Sash: High Performance, No Pattern, **Hardware:** Black, Standard Color Hand Lift, **Screen:** Fiberglass, Full Screen, **Grille Style:** Grilles Between Glass (GBG), **Grille Pattern:** Sash 1: Colonial 3w x 2h, Sash 2: No Grille, **Misc:** None

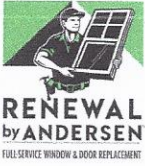

# Itemized Order Receipt

dba: Renewal By Andersen of Southern New England  
Legal Name: Southern New England Windows, LLC  
**RI #36079, MA #173245, CT #0634555, Lead Firm #1237**  
10 Reservoir Rd I Smithfield, RI 02917  
Phone: 401-349-1384 | Fax: 401-633-6602 | sales@renewalsne.com

**Ikenna Nwachukwu & Ophelia Offor**  
22 Girard Ave.  
Hartford, CT 06105  
H: (908)721-7413  
C: (908)731-2310

ID#:	ROOM:	DETAILS:
146	bed 7	<b>Window:</b> Double-Hung, 1:1, Slope Sill Insert, Traditional Checkrail, Exterior Black, Interior Black, <b>Glass:</b> All Sash: High Performance, No Pattern, <b>Hardware:</b> Black, Standard Color Hand Lift, <b>Screen:</b> Fiberglass, Full Screen, <b>Grille Style:</b> Grilles Between Glass (GBG), <b>Grille Pattern:</b> Sash 1: Colonial 3w x 2h, Sash 2: No Grille, <b>Misc:</b> None
147	bed 8	<b>Window:</b> Double-Hung, 1:1, Slope Sill Insert, Traditional Checkrail, Exterior Black, Interior Black, <b>Glass:</b> All Sash: High Performance, No Pattern, <b>Hardware:</b> Black, Standard Color Hand Lift, <b>Screen:</b> Fiberglass, Full Screen, <b>Grille Style:</b> Grilles Between Glass (GBG), <b>Grille Pattern:</b> Sash 1: Colonial 3w x 2h, Sash 2: No Grille, <b>Misc:</b> None
148	bed 8	<b>Window:</b> Double-Hung, 1:1, Slope Sill Insert, Traditional Checkrail, Exterior Black, Interior Black, <b>Glass:</b> All Sash: High Performance, No Pattern, <b>Hardware:</b> Black, Standard Color Hand Lift, <b>Screen:</b> Fiberglass, Full Screen, <b>Grille Style:</b> Grilles Between Glass (GBG), <b>Grille Pattern:</b> Sash 1: Colonial 3w x 2h, Sash 2: No Grille, <b>Misc:</b> None
149	bed 9	<b>Window:</b> Double-Hung, 1:1, Slope Sill Insert, Traditional Checkrail, Exterior Black, Interior Black, <b>Glass:</b> All Sash: High Performance, No Pattern, <b>Hardware:</b> Black, Standard Color Hand Lift, <b>Screen:</b> Fiberglass, Full Screen, <b>Grille Style:</b> Grilles Between Glass (GBG), <b>Grille Pattern:</b> Sash 1: Colonial 3w x 2h, Sash 2: No Grille, <b>Misc:</b> None





# Itemized Order Receipt

dba: Renewal By Andersen of Southern New England

Legal Name: Southern New England Windows, LLC

RI #36079, MA #173245, CT #0634555, Lead Firm #1237

10 Reservoir Rd | Smithfield, RI 02917

Phone: 401-349-1384 | Fax: 401-633-6602 | sales@renewalsne.com

Ikena Nwachukwu & Ophelia Offor

22 Girard Ave.

Hartford, CT 06105

H: (908)721-7413

C: (908)731-2310

**ID#: ROOM: DETAILS:**

150	bed 9	<p><b>Window:</b> Double-Hung, 1:1, Slope Sill Insert, Traditional Checkrail, Exterior Black, Interior Black, <b>Glass:</b> All Sash: High Performance, No Pattern, <b>Hardware:</b> Black, Standard Color Hand Lift, <b>Screen:</b> Fiberglass, Full Screen, <b>Grille Style:</b> Grilles Between Glass (GBG), <b>Grille Pattern:</b> Sash 1: Colonial 3w x 2h, Sash 2: No Grille, <b>Misc:</b> None</p>
151	play room	<p><b>Specialty:</b> Circle Top, Base Frame, Exterior Black, Interior Black, <b>Glass:</b> All Sash: High Performance, No Pattern, <b>Grille Style:</b> Grilles Between Glass (GBG), <b>Grille Pattern:</b> All Sash: Renaissance 6w, <b>Misc:</b> None</p>
152	2nd Stairs	<p><b>Window:</b> Double-Hung, 1:1, Slope Sill Insert, Traditional Checkrail, Exterior Black, Interior Black, <b>Glass:</b> Sash 1: High Performance, No Pattern, Sash 2: High Performance, No Pattern, Tempered Glass, <b>Hardware:</b> Black, Standard Color Hand Lift, <b>Screen:</b> Fiberglass, Full Screen, <b>Grille Style:</b> Grilles Between Glass (GBG), <b>Grille Pattern:</b> Sash 1: Colonial 3w x 2h, Sash 2: No Grille, <b>Misc:</b> None</p>
153	3 stairway	<p><b>Window:</b> Double-Hung, 1:1, Slope Sill Insert, Traditional Checkrail, Exterior Black, Interior Black, <b>Glass:</b> All Sash: High Performance, No Pattern, <b>Hardware:</b> Black, Standard Color Hand Lift, <b>Screen:</b> Fiberglass, Full Screen, <b>Grille Style:</b> Grilles Between Glass (GBG), <b>Grille Pattern:</b> Sash 1: Colonial 3w x 2h, Sash 2: No Grille, <b>Misc:</b> None</p>

<b>WINDOWS: 51</b>	<b>PATIO DOORS: 0</b>	<b>SPECIALTY: 2</b>	<b>MISC: 4</b>	<b>TOTAL \$86,539</b>
--------------------	-----------------------	---------------------	----------------	-----------------------



Renewal by Andersen is committed to our customers' safety by complying with the rules and lead-safe work practices specified by the EPA.















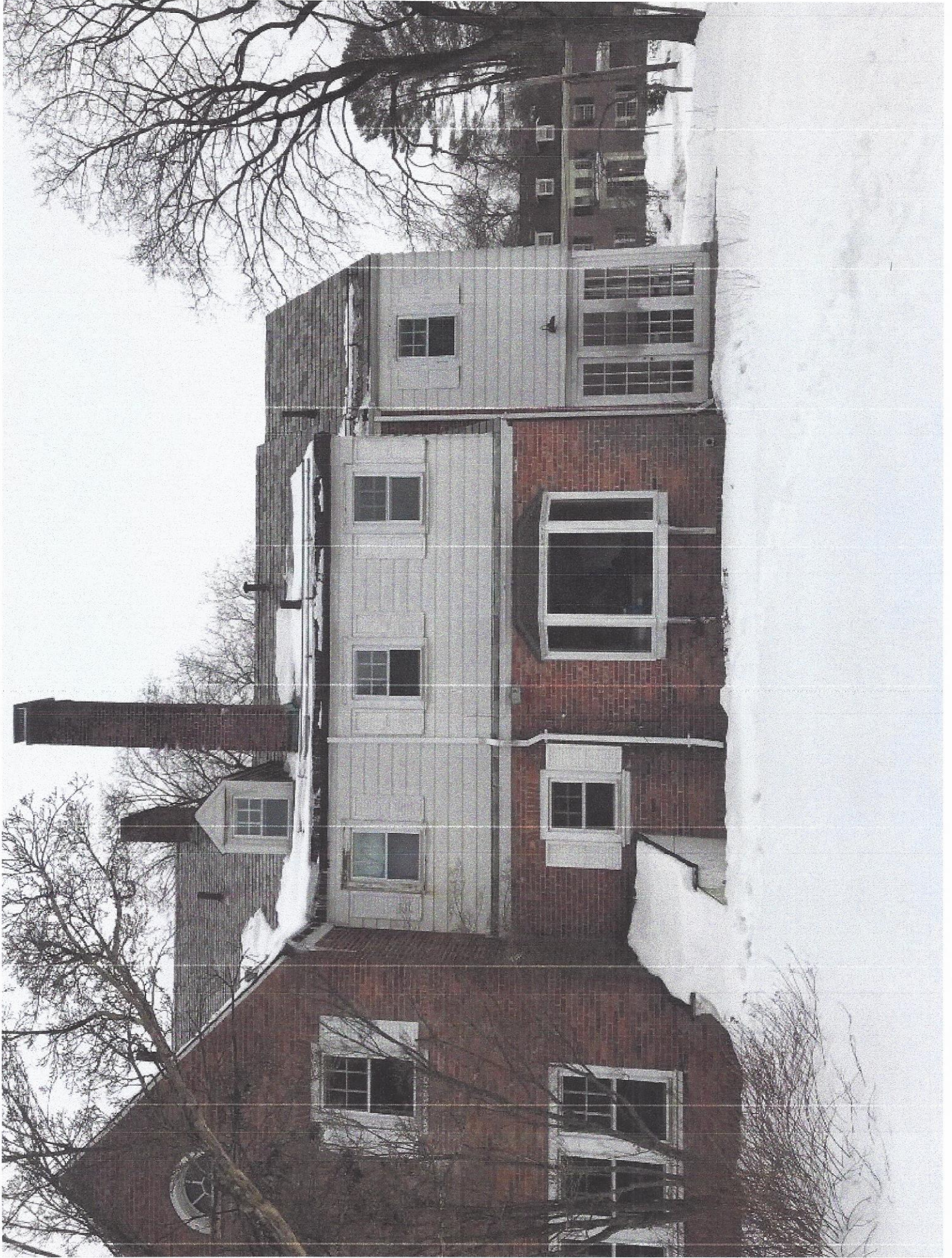







**DOUBLE-HUNG WINDOW****ADVANTAGES AND APPLICATIONS**

A double-hung window consists of two vertically sliding sash in a single frame. Both sash are counterbalanced by a spring-powered block-and-tackle balance mounted on the side of each sash. Tilt latches for each sash allow inward tilting for easy cleaning. Upper and lower sash are securely closed by use of a cam-type sash lock. An insect screen is installed into the outside track.

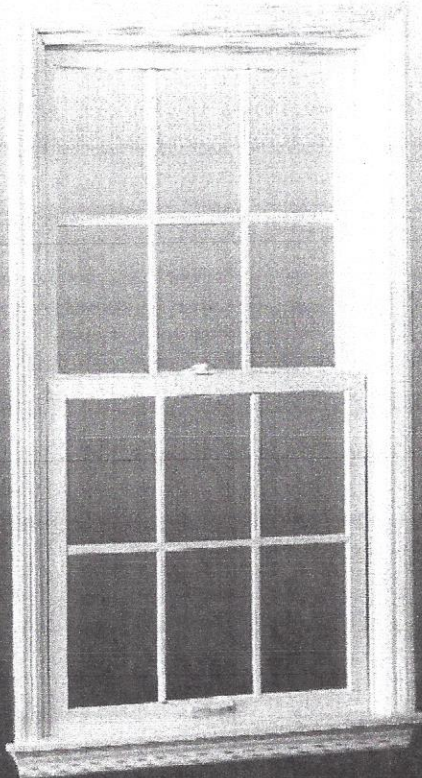

*Double-Hung  
Replacement Windows*

**ADVANTAGES**

- Both sash can be operated for ventilation at top and bottom of window.
- Both sash can be tilted inward for easy cleaning.
- Patented Fibrex® material is stronger than vinyl, providing greater durability.
- Fibrex material with low-maintenance capstock gives a rich, low-luster finish to sash and frame, similar to painted wood.
- Smooth radius surfaces on the frame and sash are pleasing to the eye and easier to clean.
- Mortise-and-tenon appearance on the interior and exterior sash corners gives a traditional, hand-crafted look.
- Full-perimeter weatherstrip provides superior weathertightness while still allowing easy sash operation.
- Sash are counterbalanced by a spring-powered block-and-tackle balance mounted on the side and matched to the weight of each individual sash.

**APPLICATIONS**

- Excellent choice for homes and condominiums where traditional styling is important; appropriate for many restoration projects.
- Suitable in areas facing walkways, decks and other traffic areas because sash do not project outward.
- Convenient in areas where the sash need to be cleaned from the interior.
- Visually compatible with other Renewal by Andersen® products.



STANDARD FEATURES

DOUBLE-HUNG WINDOW



A sloped sill insert double-hung window corner section is shown here, though standard features are the same as for flat sill insert or full-frame double-hung windows.

Failure to follow our painting and/or staining instructions could hamper window performance and will nullify the Limited Warranty. See the General Guidelines section of this manual for more information.

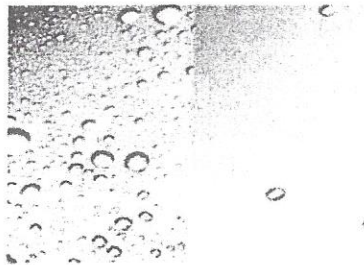
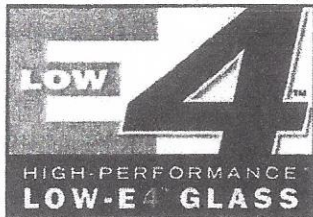

Regular Glass

High-Performance™ Low-E4™ Glass

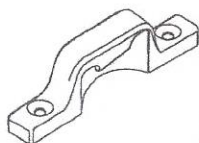

= Keeper

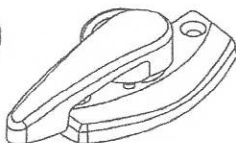

Sash Lock

Described below are features that contribute to the casement window's low maintenance, energy efficiency, ease of operation, and pleasing appearance.

- **Frame** – Made of rigid Fibrex® material, a unique structural composite of wood fibers and a special thermoplastic polymer. Developed by Andersen®, Fibrex® material combines the strength and stability of wood with the low-maintenance features of our time-tested Perma-Shield® cladding.
- **Sash** – Constructed of Fibrex® material. Fusion-welding provides durable, watertight corners. The smooth, radiused sash complements the frame. An exterior “fillet” bead of high-performance silicone sealant provides a watertight seal between glass and sash.
  - **Glazing** – High-Performance™ LoE4\* glass with an inert, energy-efficient gas, is standard for every window. Glass is placed into sash before welding for a strong, weather-tight assembly. An exterior “fillet” bead of high-quality silicone sealant provides a watertight seal between glass and sash. See Options on next page for other glass choices.
- **Glass spacer** – The patented low-conductivity spacer is made of stainless steel and resists heat transfer four to five times better than aluminum spacers used by many other manufacturers.
- **Low-maintenance exterior coating**—A highly durable microscopic coating of titanium dioxide (TiO<sub>2</sub>) is applied and bonded to the exterior glass surface during the glass manufacturing process. High-Performance Low-E4 glass is self-activating by exposure to sunlight. When activated by sunlight, it loosens dirt, dust and organic material which are then washed away by rain. The glass dries faster and reduces water spotting by up to 99%. (See illustration below.)

\*LoE4 is a registered trademark of Cardinal IG Company.

The unique exterior coating works similarly to a rechargeable battery. Once the coating is activated or “charged,” it will hold its activation for some time. The more sunlight it receives, the better the activation. When re-exposed to sunlight, the coating will recharge after periods of

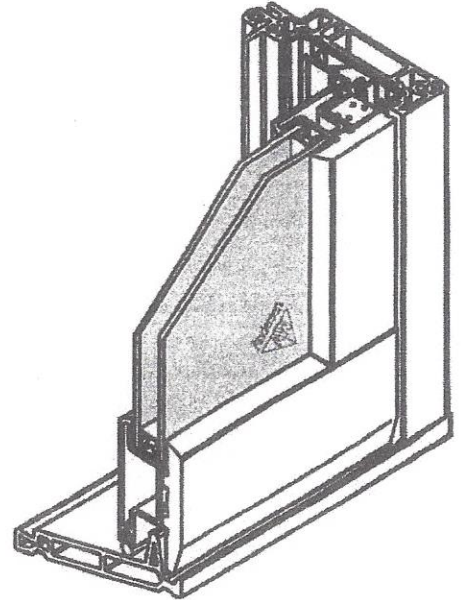

**OPTIONS, cont.**  
DOUBLE-HUNG WINDOW

- **Available Grille Types**— Three options are available. The interior and exterior sides of the grilles are colored to complement the overall window color(s). Consult the color combination charts in each window product section for detailed color information.

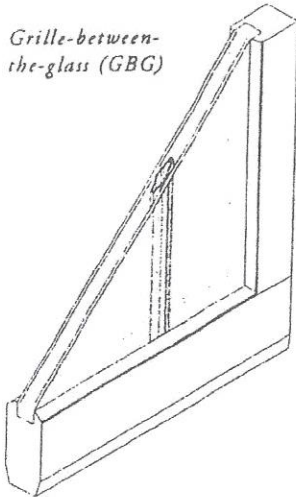

**Grille-Between-the-Glass (GBG)**

Sculpted aluminum grille members are manufactured between the glass panes, and are available in two widths.

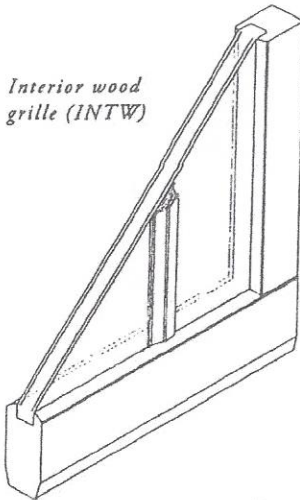
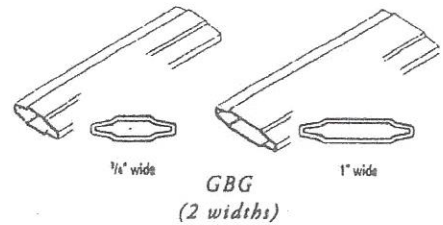

**Interior Wood Grille (INTW)**

With the option of hardwood maple or oak, these grilles snap into clips placed around the interior side of the sash and may be removed to clean the glass. These high definition profile interior wood grilles are available in two different widths.

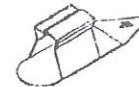
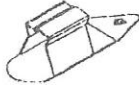
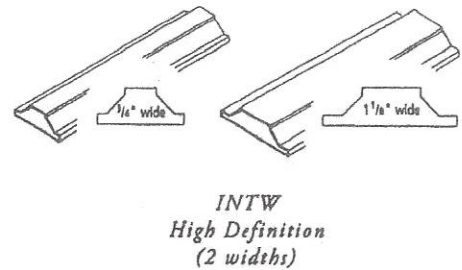

*Interior wood grille clip*

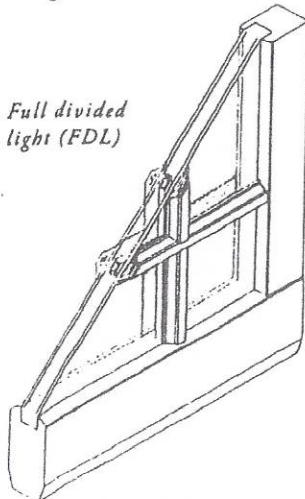

**Full Divided Light Grille (FDL)**

FDL grilles provide the classic look of a true divided light window. The high definition profile exterior grille is made from Fibrex® material and is available in two different widths. Between the glass panes, an aluminum spacer stands slightly away from each pane to maintain superior thermal performance. The high definition profile interior wood grille is available in either hardwood maple or oak and in two different widths, and may be permanently applied or removable.

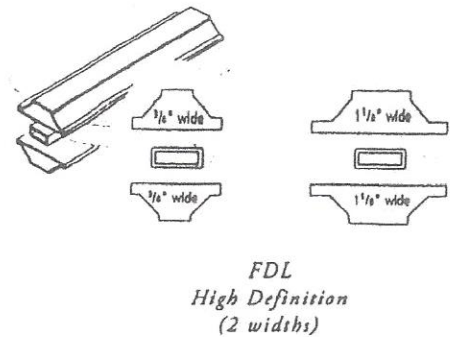



**DOUBLE-HUNG WINDOW****ADVANTAGES AND APPLICATIONS**

A double-hung window consists of two vertically sliding sash in a single frame. Both sash are counterbalanced by a spring-powered block-and-tackle balance mounted on the side of each sash. Tilt latches for each sash allow inward tilting for easy cleaning. Upper and lower sash are securely closed by use of a cam-type sash lock. An insect screen is installed into the outside track.

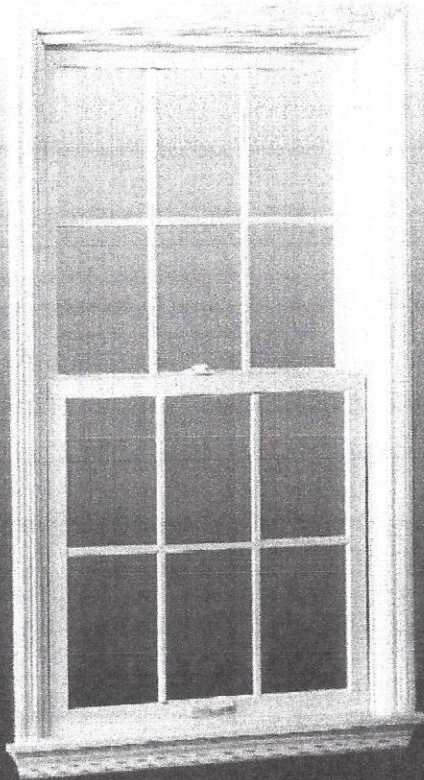

*Double-Hung  
Replacement Windows*

**ADVANTAGES**

- Both sash can be operated for ventilation at top and bottom of window.
- Both sash can be tilted inward for easy cleaning.
- Patented Fibrex® material is stronger than vinyl, providing greater durability.
- Fibrex material with low-maintenance capstock gives a rich, low-luster finish to sash and frame, similar to painted wood.
- Smooth radius surfaces on the frame and sash are pleasing to the eye and easier to clean.
- Mortise-and-tenon appearance on the interior and exterior sash corners gives a traditional, hand-crafted look.
- Full-perimeter weatherstrip provides superior weathertightness while still allowing easy sash operation.
- Sash are counterbalanced by a spring-powered block-and-tackle balance mounted on the side and matched to the weight of each individual sash.

**APPLICATIONS**

- Excellent choice for homes and condominiums where traditional styling is important; appropriate for many restoration projects.
- Suitable in areas facing walkways, decks and other traffic areas because sash do not project outward.
- Convenient in areas where the sash need to be cleaned from the interior.
- Visually compatible with other Renewal by Andersen® products.



STANDARD FEATURES

DOUBLE-HUNG WINDOW



A sloped sill insert double-hung window corner section is shown here, though standard features are the same as for flat sill insert or full-frame double-hung windows.

Failure to follow our painting and/or staining instructions could hamper window performance and will nullify the Limited Warranty. See the General Guidelines section of this manual for more information.

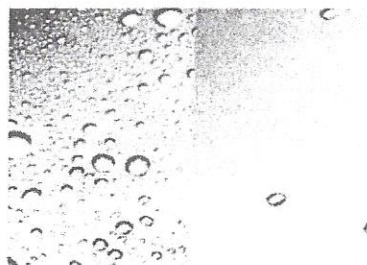
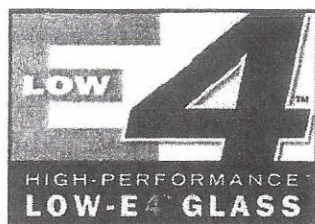

Regular Glass

High-Performance™ Low-E4™ Glass

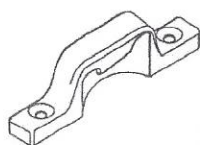

= Keeper

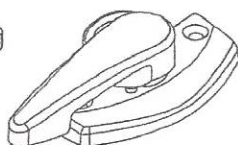

Sash Lock

Described below are features that contribute to the casement window's low maintenance, energy efficiency, ease of operation, and pleasing appearance.

- **Frame** – Made of rigid Fibrex® material, a unique structural composite of wood fibers and a special thermoplastic polymer. Developed by Andersen®, Fibrex® material combines the strength and stability of wood with the low-maintenance features of our time-tested Perma-Shield® cladding.
- **Sash** – Constructed of Fibrex® material. Fusion-welding provides durable, watertight corners. The smooth, radiused sash complements the frame. An exterior “fillet” bead of high-performance silicone sealant provides a watertight seal between glass and sash.
- **Glazing** – High-Performance™ LoE4\*\* glass with an inert, energy-efficient gas, is standard for every window. Glass is placed into sash before welding for a strong, weather-tight assembly. An exterior “fillet” bead of high-quality silicone sealant provides a watertight seal between glass and sash. See Options on next page for other glass choices.

\*LoE4 is a registered trademark of Cardinal IG Company.

The unique exterior coating works similarly to a rechargeable battery. Once the coating is activated or “charged,” it will hold its activation for some time. The more sunlight it receives, the better the activation. When re-exposed to sunlight, the coating will recharge after periods of

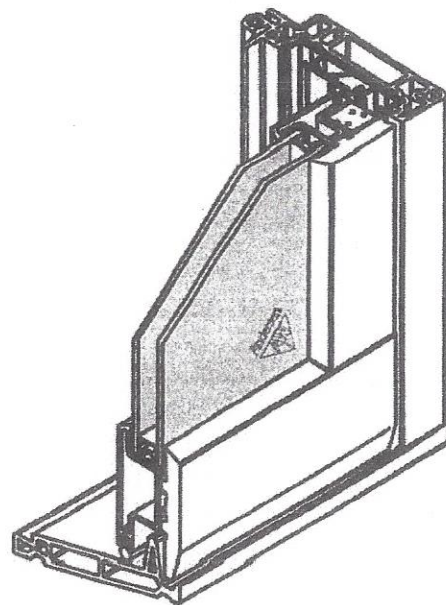

**OPTIONS, cont.**

**DOUBLE-HUNG WINDOW**

- **Available Grille Types**— Three options are available. The interior and exterior sides of the grilles are colored to complement the overall window color(s). Consult the color combination charts in each window product section for detailed color information.

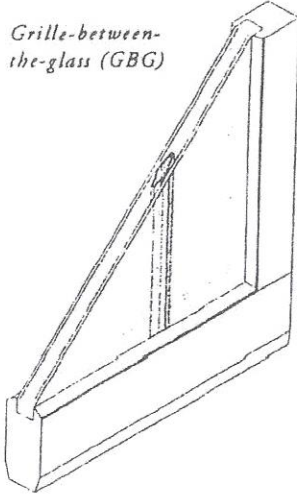

*Grille-between-the-glass (GBG)*

**Grille-Between-the-Glass (GBG)**

Sculpted aluminum grille members are manufactured between the glass panes, and are available in two widths.

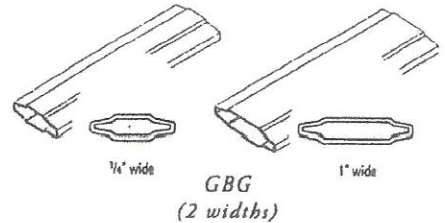

*GBG  
(2 widths)*

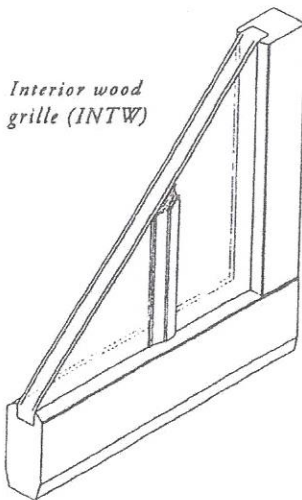

*Interior wood grille (INTW)*

**Interior Wood Grille (INTW)**

With the option of hardwood maple or oak, these grilles snap into clips placed around the interior side of the sash and may be removed to clean the glass. These high definition profile interior wood grilles are available in two different widths.

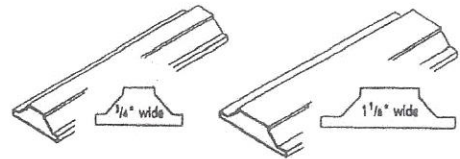

*INTW  
High Definition  
(2 widths)*

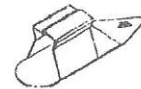
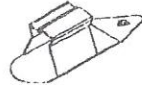

*Interior wood grille clip*

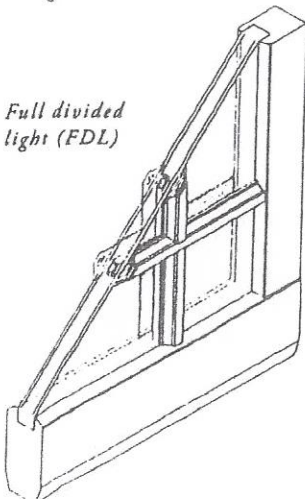

*Full divided light (FDL)*

**Full Divided Light Grille (FDL)**

FDL grilles provide the classic look of a true divided light window. The high definition profile exterior grille is made from Fibrex® material and is available in two different widths. Between the glass panes, an aluminum spacer stands slightly away from each pane to maintain superior thermal performance. The high definition profile interior wood grille is available in either hardwood maple or oak and in two different widths, and may be permanently applied or removable.

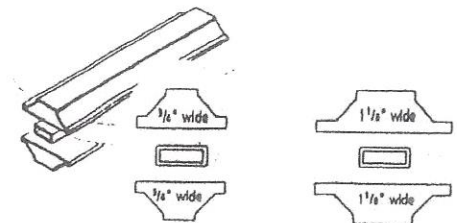

*FDL  
High Definition  
(2 widths)*